



EVERPURE® · SHURFLO®



OFFICE COFFEE & WATER AND VENDING CATALOG

VOLUME SIX | ISSUED JANUARY 1, 2016



EVERPURE® · SHURFLO®

NEW
FOR
2016

Lead Reduction,
Plus Chlorine Taste & Odor,
Submicron Particulate**
and Cyst** Reduction with
Bacteriostatic Control**

4FC-LS also offers
Scale Inhibition



Everpure®
4FC-L and 4FC-LS
Lead Reduction Cartridges
(Page 4)

Chlorine Taste & Odor,
Particulate, TDS,
Cyst** and
Scale Reduction

WATER
EFFICIENT
RO SYSTEM



Everpure
LVRO-75HE
RO System
(Page 11)

Hardness Reduction, Mineral Stabilization
and Corrosion Inhibition



Everpure
Claris™ Ultra
Softening Cartridges
(Page 6)

*By mechanical means.

† See individual system specification sheets for performance claims and FIFRA registration information.

Claris™ is a trademark of Aquis, GmbH.

TABLE OF CONTENTS

2	OFFICE WATER	13	WATER TESTING	19	ELECTRIC DELIVERY PUMPS
6	OFFICE COFFEE SERVICE (OCS)	14	VALUE FILTRATION	20	FILTRATION GUIDE
9	VENDING	15	WATER APPLIANCES / ACCESSORIES	22	PRICE LIST / INDEX
10	FILTER HEADS	16	WATER BOOST SYSTEMS	24	THE PENTAIR® EVERPURE® ADVANTAGE
10	REVERSE OSMOSIS	17	REVERSE OSMOSIS PUMPS / ACCESSORIES		
12	SPECIAL PURPOSE				

Contact Your Pentair Everpure Representative for more information on the following programs:

- Everpure Cartridge Tracking System (ECTS)
- Everpure Auth2ority Training Program
- Five-Year Warranty on Most Systems
- Free Freight Program – If you are authorized to order direct from Pentair Everpure, orders **\$4,000** and above qualify for free freight!

What's your filter size?

Everpure Replacement Filter Cartridges from Pentair are manufactured in four different height configurations.

Each cartridge has a size designation of:

- 2-size = 10.25" [26.04 cm] tall
- 4-size = 14.50" [36.83 cm] tall
- 6-size = 17" [43.18 cm] tall
- 7-size = 20.75" [52.71 cm] tall

For example:

- 2-size = OCS², 2K-Plus and 2CLM cartridges
- 4-size = BH², 4C, 4K-Plus, S101, TFC cartridges
- 6-size = OW200L cartridge
- 7-size = 7T0, 7CB5 cartridges

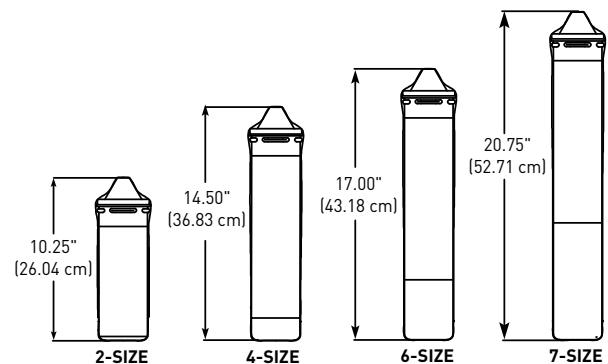

Flood Protection

ELTEK® WATER BLOCK



- Overflow safety device for coffee brewers, coolers, chillers, heaters, vending machines, ice machines and more
- Automatically shuts off if preset volume is exceeded
- Automatically resets if water volume preset is not exceeded
- Ten-position dial sets maximum flow volume
- No external energy source required
- Not recommended for reverse osmosis (RO) or ice flaker installation as an RO system by nature can produce permeate water for long periods of time which will unnecessarily trip the Water Block

PART NO	DESCRIPTION	PACK QTY	LIST PRICE EA
A EV950300	Water Block	200	\$27.71
A EV950305	Water Block	25	28.42
B EV950320	Water Block Reset Device	200	15.75
B EV950325	Water Block Reset Device	25	16.13
- EV313861	Adaptor: 3/4" male garden hose (both ends), black	1	1.33
C EV311840	Wall Mount Clip: black	1	1.63

Water Pressure Regulators

SHURFLO® WATER PRESSURE REDUCER VALVES

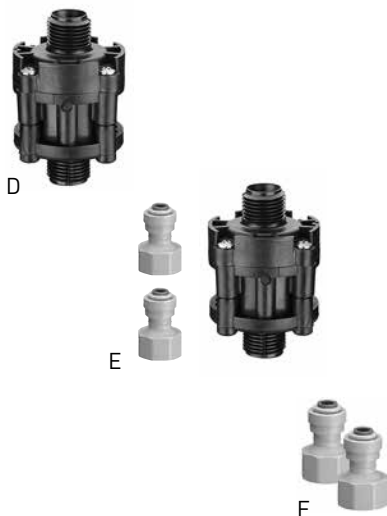

- Reduces the water pressure from city mains to provide a lower and safer pressure for plumbing and appliances
- Regulates water line pressure for delivery consistency and better appliance performance
- Low-cost investment delivers valuable benefits

PART NO	DESCRIPTION	PACK QTY	LIST PRICE EA
D 183-130-NF	1/2" NST, 30 PSI [2.07 bar], w/o fittings.	12	\$17.30
D 183-150-NF	1/2" NST, 50 PSI [3.45 bar], w/o fittings.	12	17.30
D 183-165-NF	1/2" NST, 65 PSI [4.48 bar], w/o fittings.	12	17.30
E 183-165-QC14	65 PSI [4.48 bar], 1/4" [0.64 cm], John Guest® (JG) Fittings.	12	21.91
E 183-165-QC38	65 PSI [4.48 bar], 3/8" [0.95 cm], JG Fittings.	12	21.91
F EV313526	Pair of 1/2" [12.7 mm] and 1/4" [6.4 mm], JG Fittings.	12	11.18
F EV313527	Pair of 1/2" [12.7 mm] and 3/8" [9.5 mm], JG Fittings.	12	11.18

Flushing/Sanitizing Cartridge

EVERPURE® MODEL JT FLUSHING/SANITIZING CARTRIDGES

Flushing and Sanitizing is Simple and Easy



- Preferred way to introduce sanitizing agents, such as bleach, into all water-using appliances through an existing Everpure filter head
- Eliminates the need for component disassembly
- Recommended by National Automatic Merchandising Association (NAMA®)

PART NO	DESCRIPTION	LENGTH INCHES / CM	PACK QTY	LIST PRICE EA
G EV960800	4JT	14.05 / 36.83	1	\$37.29
- EV960810	2JT	10.25 / 26.04	1	37.29

Bacteria Reduction** †

MicroGuard Filters
Reduce Bacteria
by 99.9999%* †

Purifying Quick-
Change Filter for
Bacteria Reduction* †



EVERPURE® MICROGUARD® PRO 2 & MICROGUARD PRO 4 CARTRIDGES

- Multi-stage cartridges contain both membrane and carbon block filtration technologies
- 0.15 micron filtration by mechanical means†, rated for chlorine taste & odor
- Capillary membrane filtration reduces:
 - 99.9999% of bacteria by mechanical means†
 - cysts such as *Cryptosporidium* and *Giardia* by mechanical means†
 - asbestos fibers

	PART NO	DESCRIPTION	CAPACITY GALLONS/LITRES	PACK QTY	LIST PRICE EA
A	EV963701	MicroGuard Pro 2 Cartridge	2,200 / 8,328	6	\$67.50
B	EV963702	MicroGuard Pro 4 Cartridge	3,600 / 13,627	6	75.42

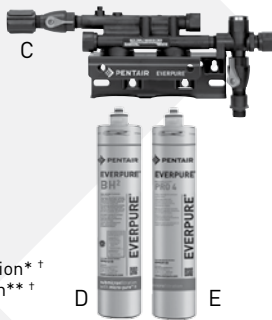

Bacteria Reduction* †
with Prefiltration*** †

EVERPURE MICROGUARD PLUS POU WATER TREATMENT SYSTEM

- 1/2 micron precoat filtration by mechanical means†
- Multi-stage cartridge contains membrane plus carbon block technology
- Proprietary media effectively inhibits the growth of bacteria to extend product life†

	PART NO	DESCRIPTION	CAPACITY GALLONS/LITRES	PACK QTY	LIST PRICE EA
C	EV927224	Twin Series Head	-	1	\$105.00
D	EV961251	BH ² Cartridge	3,000 / 11,356	6	41.67
E	EV963702	MicroGuard Pro 4 Cartridge	3,600 / 13,627	6	75.42

Chloramines & Particulate Reduction

The only 10" Cartridge
NSF-Certified for
Chloramines Reduction

Ideal for
Drinking Water



Perfect for
Coffee
Brewing

EVERPURE 2CLM & 2CLM-S CARTRIDGES

- 1/2 micron precoat filtration by mechanical means†
- Rated for chloramines and particulate reduction
- Reduces damage to rubber and synthetic system components
- Scale inhibition (EV969296 only)

	PART NO	DESCRIPTION	CAPACITY (GALLONS / LITRES)	PACK QTY	LIST PRICE EA
F	EV969286	2CLM Cartridge	1,500 / 5,678	6	\$43.75
G	EV969296	2CLM-S Cartridge	1,500 / 5,678	6	47.08

*Membrane filtration provides 99.9999% reduction of bacteria and 99.9999% reduction of virus by mechanical means.

**By mechanical means.

†See individual system specification sheets for performance claims and FIFRA registration information.

Chlorine Taste & Odor, Particulate, Cyst[†], Limescale & Lead Reduction

EVERPURE® 2H-L & 4H-L CARTRIDGES

- 1/2 micron precoat filtration by mechanical means*
- Rated for chlorine taste & odor, particulate and lead reduction
- Cyst reduction by mechanical means*
- Scale inhibition

PLUS added Lead Protection



PART NO	DESCRIPTION	CAPACITY (GALLONS / LITRES)	PACK QTY	LIST PRICE EA
A	EV963426	2H-L Cartridge	750 / 2,839	12 \$32.96
B	EV963526	4H-L Cartridge	1,000 / 3,785	6 35.21

EVERPURE 4FC-L & 4FC-LS CARTRIDGES

- 1/2 micron precoat filtration by mechanical means*
- Rated for chlorine, taste & odor, particulate and lead reduction below 15 ppb
- Scale inhibition (EV969316 only)
- Cyst reduction by mechanical means*
- Proprietary Fibredyne™ filtration media effectively inhibits growth of bacteria on the filter media that can decrease product life*

High Capacity Lead Protection



PART NO	DESCRIPTION	LEAD REMOVAL CAPACITY** (GALLONS / LITRES)	TASTE & ODOR CAPACITY** (GALLONS / LITRES)	PACK QTY	LIST PRICE EA
C	EV969310	4FC-L Cartridge	4,900 / 18,548	9,800 / 37,097	6 \$53.33
D	EV969316	4FC-LS Cartridge	4,900 / 18,548	9,800 / 37,097	6 55.83

EVERPURE OW200L CARTRIDGE

- 1/2 micron precoat filtration by mechanical means*
- Rated for chlorine taste & odor, particulate and asbestos reduction
- Cyst reduction by mechanical means*
- NSF listed for up to 99% reduction of both dissolved and particulate lead, and total trihalomethane (TTHM) reduction
- Also features limescale reduction

PLUS 99% Reduction of Dissolved and Particulate Lead, and TTHM Reduction



PART NO	DESCRIPTION	CAPACITY (GALLONS / LITRES)	PACK QTY	LIST PRICE EA
E	EV961906	OW200L Cartridge	480 / 1,817	6 \$50.83

EVERPURE OW2-PLUS & OW4-PLUS CARTRIDGES

- 1/2 micron precoat filtration by mechanical means*
- Rated for chlorine taste & odor, particulate, asbestos and lead reduction
- Cyst reduction by mechanical means*
- Provides bacteriostatic protection which inhibits the growth of bacteria on the filter media that can decrease product life*
- KDF® media inhibits limescale buildup that can damage equipment
- Great for drinking water or coffee applications!
- The only 2-size cartridge with asbestos claim (EV963406)

PLUS Lead Reduction and KDF for Slime and Limescale Inhibition



PART NO	DESCRIPTION	CAPACITY (GALLONS / LITRES)	PACK QTY	LIST PRICE EA
F	EV963406	OW2-Plus Cartridge	1,000 / 3,785	6 \$41.33
G	EV963506	OW4-Plus Cartridge	2,000 / 7,571	6 50.42

*See individual system specification sheets for performance claims and FIFRA registration information.

**NSF Rated.

†By mechanical means.

††As tested by Everpure

High Flow, High Capacity, Chlorine Taste & Odor, Particulate & Cyst Reduction^{†*}



EVERPURE® 2FC & 2FC-S CARTRIDGES

- Increased capacity for extended reduction of chemical and mechanical contaminants
- Proprietary Fibredyne™ filtration media effectively inhibits the growth of bacteria on the filter media that can decrease product life*
- Exclusive precoat filtration provides superior chlorine taste & odor reduction and micro-filters dirt and particles as small as 1/2 micron in size by mechanical means*
- Flow rates up to 1.5 gpm [5.6 Lpm]
- Reduces limescale buildup (EV969176 only)

PART NO	DESCRIPTION	CAPACITY (GALLONS / LITRES)	PACK QTY	LIST PRICE EA
A EV969156	2FC Cartridge	6,000 / 22,712	6	\$38.58
B EV969176	2FC-S Cartridge	6,000 / 22,712	6	42.92

Chlorine Taste & Odor, Particulate and Cyst Reduction^{†*}



EVERPURE AC & 4C CARTRIDGES

- 1/2 micron precoat filtration by mechanical means rated for chlorine taste & odor and particulate reduction*
- Cyst reduction by mechanical means*
- Provide asbestos reduction (EV960112 only)

PART NO	DESCRIPTION	CAPACITY (GALLONS / LITRES)	PACK QTY	LIST PRICE EA
C EV960112	AC Cartridge	750 / 2,839	6	\$27.92
D EV960100	4C Cartridge	3,000 / 11,356	6	32.96

GREAT DOUBLE DUTY CARTRIDGES – USE FOR COFFEE AND POU COOLERS

Micro-Pure II with Antimicrobial Protection



EVERPURE OCS² & BH² CARTRIDGES

- 1/2 micron precoat filtration by mechanical means*
- Proprietary Micro-Pure® II filtration media effectively inhibits the growth of bacteria on the filter media that can decrease product life*
- Reduces:
 - chlorine taste & odor
 - cysts by mechanical means*
 - particulate & asbestos
- Inhibits limescale buildup
- OCS² designed for low flow, low volume coffee brewers

PART NO	DESCRIPTION	CAPACITY	PACK QTY	LIST PRICE EA
E EV961807	OCS² Cartridge	3,000 Pots or 1,500 gallons [5,678 L]	6	\$29.54
F EV961251	BH² Cartridge	6,000 Pots or 3,000 gallons [11,356 L] (Designed for Single Cup Flow Rates)	6	41.67

PLUS KDF for Slime Reduction and Limescale Inhibition



EVERPURE 2K-PLUS & 4K-PLUS CARTRIDGES

- 1/2 micron precoat filtration by mechanical means*
- KDF® media inhibits limescale buildup that can damage equipment
- Provides all the benefits of precoat filters plus reduces slime

PART NO	DESCRIPTION	CAPACITY (GALLONS / LITRES)	PACK QTY	LIST PRICE EA
G EV961266	2K-Plus Cartridge	1,500 / 5,678	6	\$35.92
H EV961276	4K-Plus Cartridge	3,000 / 11,356	6	45.00

*See individual system specification sheets for performance claims and FIFRA registration information.

†By mechanical means.

10 Micron Carbon Block

EVERPURE® 2CB-GW CARTRIDGE

- For premium single cup coffee machines
- Effectively filters out particles that affect taste
- Reduces chlorine taste & odor, dirt and cloudiness
- Protects equipment from abrasion and lowers energy costs by reducing limescale

Highly Recommended for Premium Single Cup Coffee



PART NO	DESCRIPTION	CAPACITY (GALLONS / LITRES)	PACK QTY	LIST PRICE EA
A	EV961836	2CB-GW Cartridge	6	\$30.71

5 Micron Carbon Block

EVERPURE 2CB5-S, 4CB5-S & 2FC5-S CARTRIDGES

- 5 micron carbon block filters reduce chlorine taste & odor and inhibit scale buildup

PLUS Scale Reduction



PART NO	DESCRIPTION	CAPACITY (GALLONS / LITRES)	PACK QTY	LIST PRICE EA
B	EV961722	2CB5-S Cartridge	6	\$29.04
C	EV961726	4CB5-S Cartridge	6	40.04
D	EV969186	2FC5-S Cartridge	6	41.67

EVERPURE 2CB5-K & 4CB5-K CARTRIDGES

- 5 micron carbon block filters for chlorine taste & odor reduction
- Contain KDF® media to inhibit scale buildup that can damage equipment

PLUS Slime Reduction and Scale Inhibition



PART NO	DESCRIPTION	CAPACITY (GALLONS / LITRES)	PACK QTY	LIST PRICE EA
E	EV961706	2CB5-K Cartridge	6	\$30.17
F	EV961736	4CB5-K Cartridge	6	43.33

Tailored Hardness & Limescale Protection

- Quick change decarbonator plus 5-stage filtration
- Lower upfront cost than RO and takes up less space
- Blending allows for perfect tasting specialty coffees and teas
- Eliminates cloudy iced tea

NO MORE SCALE-RELATED SERVICE CALLS

Contact your Pentair® Everpure® Broker to learn more.

Softening / Filtration

EVERPURE claris™ ultra CARTRIDGES

Effectively combines hardness reduction, mineral stabilization and corrosion inhibition by maintaining a controlled low carbonic acid level in the water.

- Consistent mineral adaptation
- Corrosion inhibition
- Inhibition of metal migration from machine parts
- Maintains pH range with high accuracy thanks to DuoBlend® technology
- Widest capacity range and ratio of all cartridges in the market



SCALE PROTECTION WITH CORROSION INHIBITION

PART NO	DESCRIPTION	PACK QTY	LIST PRICE EA
G	EV433980** Claris Ultra Small Cartridge: 594 gallon [2,250 L] capacity* for Espresso applications; 660 gallon [2,500 L] capacity* for OCS/Coffee applications.	1	\$119.93
H	EV433981** Claris Ultra Medium Cartridge: 990 gallon [3,750 L] capacity* for Espresso applications; 1,109 gallon [4,200 L] capacity* for OCS/Coffee applications.	1	167.28
I	EV433982** Claris Ultra Large Cartridge: 1,849 gallon [7,000 L] capacity* for Espresso applications; 2,245 gallon [8,500 L] capacity* for OCS/Coffee applications.	1	231.10
J	EV433983** Claris Ultra XLarge Cartridge: 2,641 gallon [10,000 L] capacity* for Espresso applications; 3,196 gallon [12,100 L] capacity* for OCS/Coffee applications.	1	275.37
K	EV433984** Claris Ultra XXLarge Cartridge: 4,358 gallon [16,500 L] capacity* for Espresso applications; 5,283 gallon [20,000 L] capacity* for OCS/Coffee applications.	1	408.16

*Capacity is based on 180 ppm incoming water @ 40% bypass and 10° Carbonate Hardness (alkalinity).
**Does not include head.

Claris™ is a trademark of Aquis, GmbH.

Softening / Filtration (Cont'd.)

PERFECT SOLUTION FOR CLOUDY ICED TEA!



EVERPURE claris™ CARTRIDGES

- Adjustable ion-selective filter tailors carbonate hardness levels in potable water
- Accommodates up to 25-30 gallons [95-114 L] per day of brewed coffee and espresso
- Flow rates up to 1.0 gpm [3.7 Lpm]

PART NO	DESCRIPTION	PACK QTY	LIST PRICE EA
A EV433910	Claris Small Cartridge: 400 gallon [1,514 L] capacity* for Espresso applications; 450 gallon [1,703 L] capacity* for Tea/Coffee applications.	1	\$105.00
B EV433911	Claris Medium Cartridge: 660 gallon [2,498 L] capacity* for Espresso applications; 790 gallon [2,990 L] capacity* for OCS/Coffee applications.	1	147.72
C EV433912	Claris Large Cartridge: 1,220 gallon [4,618 L] capacity* for Espresso applications; 1,480 gallon [5,602 L] capacity* for OCS/Coffee applications.	1	189.41
D EV433913	Claris XLarge Cartridge: 1,740 gallon [6,587 L] capacity* for Espresso applications; 2,120 gallon [8,025 L] capacity* for OCS/Coffee applications.	1	224.93
E EV433914	Claris XXL Cartridge: 2,910 gallon [11,016 L] capacity* for Espresso applications; 3,490 gallon [13,211 L] capacity* for OCS/Coffee applications.	1	346.40

Heads

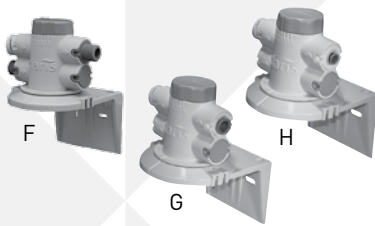

EVERPURE® claris™ HEADS

- Designed exclusively for use with Claris replacement cartridges

PART NO	DESCRIPTION	FITTINGS	PACK QTY	LIST PRICE EA
F EV433921	Claris Filter Head	3/8" [1 cm] BSP	1	\$79.26
G EV433923	Claris Filter Head	3/8" [1 cm] QC	1	79.26
H EV433925	Claris Filter Head	1/4" [0.64 cm] QC	1	79.26

Accessories



EVERPURE claris™ WATER TEST KIT

PART NO	DESCRIPTION	PACK QTY	LIST PRICE EA
I EV433940	Claris Water Test Kit	1	\$29.13

Scale Inhibitor

Simple and Easy Deliming



EVERPURE SCALEKLEEN® SCALE REMOVER

- The smart, environmentally safe way to delime equipment and other water-using appliances

PART NO	DESCRIPTION	PACK QTY	LIST PRICE EA
J EV979831	Packets: 1.75 oz [50 gram] (English/French/Spanish)	96	\$2.17
K EV979833	Packets: 7 oz [200 gram] (English/French/Spanish)	24	4.46
L EV979835	Canister: 2.20 lbs. [1 kg.] (English/French/Spanish)	4	17.54

Flushing and Sanitizing is Simple and Easy



EVERPURE MODEL JT FLUSHING CARTRIDGES

- Recommended by National Automatic Merchandising Association (NAMA®)
- Preferred way to introduce Scalekleen Scale Remover into all water-using appliances through an existing Everpure filter head
- Eliminates the need for component disassembly

PART NO	DESCRIPTION	LENGTH INCHES / CM	PACK QTY	LIST PRICE EA
M EV960800	4JT Flushing/Sanitizing Cartridge	14.50 / 36.83	1	\$37.29
- EV960810	2JT Flushing/Sanitizing Cartridge	10.25 / 26.04	1	37.29

*Typical capacity based on 100DH or 180ppm carbonate hardness (alkalinity).

Claris™ is a trademark of Aquis, GmbH.

In-Line Filters

EVERPURE® OCS ECONOMICAL IN-LINE FILTERS

- High and standard capacity models
- All models offer chlorine taste & odor (T&O) reduction; select models offer scale control
- Fittings either 1/4" [0.6 cm] FPT or 1/4" [0.6 cm], John Guest® (JG)



A



B



C



D



E



F

PART NO	DESCRIPTION	CAPACITY GALLONS / LITRES	FITTINGS	PACK QTY	LIST PRICE EA
A EV910007	IN-12 10" High Capacity Granular Activated Carbon Filter with Scale Control.	4,800 / 18,170	1/4" FPT	6	\$8.05
- EV910086	IN-12 10" High Capacity Granular Activated Carbon Filter with Scale Control.	4,800 / 18,170	1/4" JG	6	18.67
B EV910067	IN-6 PG-S 6" 100% Phosphate Filter for Scale Prevention Only.	6 months	1/4" FPT	6	10.39
- EV910008	IN-10 10" Granular Activated Carbon Filter with Scale Control.	2,400 / 9,085	1/4" FPT	6	7.29
C EV910006	IN-10 10" Granular Activated Carbon Filter with Scale Control.	2,400 / 9,085	1/4" JG	6	10.34
D EV910068	IN-10 CK 10" KDF®-55D**/Carbon Filter for T&O Reduction with Scale & Slime Prevention.	5,000 / 18,927	1/4" FPT	6	12.94

IN-LINE FILTER CARTRIDGE CLIPS

PART NO	DESCRIPTION	PACK QTY	LIST PRICE EA
E 244454	For Standard In-Line Filters, 2.0" [5.1 cm].	1	\$1.67
F 244455	For OCS Premium and High Capacity In-Lines, 2-1/2" [6.4 cm].	1	1.24

Traditional In-Line Filters

- Pentek® Filters by Pentair® offered with pressed-in JG fittings
- Models available to reduce sediment, chlorine taste & odor, lead and other contaminants
- Feature cyst reduction by mechanical means* [255649-43 only]
- Contain phosphate for scale reduction [255599-43 only]



G-K

PART NO	DESCRIPTION	FITTINGS	PACK QTY	LIST PRICE EA
G 255615-43	CB Filter: 2" x 10", 1 Micron	1/4" JG	12	16.75
H 255599-43	GAC w/Phosphate Filter: 2" x 10"	1/4" JG	12	12.46
I 255525-43	CC Shell Filter: 2" x 10"	1/4" JG	12	9.38
J 255579-43	Sediment Filter: 2" x 10", 5 Micron	1/4" JG	12	13.07
K 255649-43	Lead/Cyst* Filter: 2" x 10", 1 Micron	1/4" JG	12	19.33
- 255553-43	CC Shell with KDF®*** Filter: 2" x 10"	1/4" PPT	12	12.29

LVPO (Low Volume Per Outlet) Filtration

EVERPURE LVPO F3 FILTRATION SYSTEM

- Reduces limescale, sediment and chlorine taste & odor
- Includes 3/8" barb quick-connect ball valves, filter bypass, filter and mounting brackets

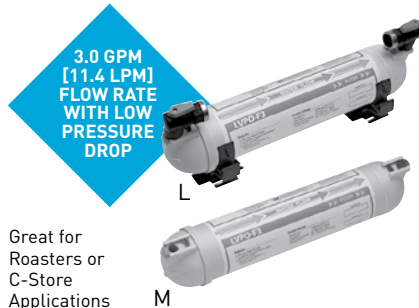

Great for Roasters or C-Store Applications

L

M

PART NO	DESCRIPTION	CAPACITY GALLONS / LITRES	PACK QTY	LIST PRICE EA
L 94-751-01	LVPO F3 Starter Kit	6,000 / 22,712	1	\$76.47
M 94-470-01	LVPO F3 Replacement Cartridge	6,000 / 22,712	12	58.82
- 84-1204-00	Ball Valves: w/o-ring kit	-	1 set	41.76
- 21-1500-00	Wall Clip Base	-	1	9.26

*See individual system specification sheets for performance claims and FIFRA registration information.

**KDF media inhibits scale buildup that can damage equipment.

Chlorine Taste & Odor, Scale Inhibition and/or Slime & Particulate Reduction



PLUS Limescale Inhibitor for Premium Coffee Applications (EV961100 only)

EVERPURE® 4C & 4H CARTRIDGES

- Powdered formula provides a more even feed with dramatic results
- 1/2 micron precoat filter rated for:
 - chlorine taste & odor
 - particulate reduction by mechanical means*
 - cyst reduction by mechanical means*
- Feature asbestos and limescale reduction (EV961100 only)

PART NO	DESCRIPTION	CAPACITY GALLONS / LITRES	PACK QTY	LIST PRICE EA	
A	EV960100	4C Cartridge	3,000 / 11,356	6	\$32.96
B	EV961100	4H Cartridge	3,000 / 11,356	6	41.67



PLUS KDF for Slime Reduction and Scale Control for Premium Coffee Applications

EVERPURE 2K-PLUS & 4K-PLUS CARTRIDGES

- 1/2 micron precoat filtration by mechanical means*
- KDF® media inhibits limescale buildup that can damage equipment*
- Provides all the benefits of precoat filters plus reduces slime

PART NO	DESCRIPTION	CAPACITY GALLONS / LITRES	PACK QTY	LIST PRICE EA	
C	EV961266	2K-Plus Cartridge	1,500 / 5,678	6	\$35.92
D	EV961276	4K-Plus Cartridge	3,000 / 11,356	6	45.00

5 Micron Carbon Block for Chlorine Taste & Odor Reduction



Contains KDF Media for Scale** and Slime Control

EVERPURE 2CB5-K & 4CB5-K CARTRIDGES

PART NO	DESCRIPTION	CAPACITY GALLONS / LITRES	PACK QTY	LIST PRICE EA	
E	EV961706	2CB5-K Cartridge	3,000 / 11,356	6	\$30.17
F	EV961736	4CB5-K Cartridge	6,000 / 22,712	6	43.33



Chlorine Taste & Odor Reduction

EVERPURE 2CB5 & 4CB5 CARTRIDGES

PART NO	DESCRIPTION	CAPACITY GALLONS / LITRES	PACK QTY	LIST PRICE EA	
G	EV961705	2CB5 Cartridge	3,000 / 11,356	6	\$26.63
H	EV961716	4CB5 Cartridge	6,000 / 22,712	6	36.83



PLUS Scale Control for Premium Coffee Applications

EVERPURE 2CB5-S & 4CB5-S CARTRIDGES

PART NO	DESCRIPTION	CAPACITY GALLONS / LITRES	PACK QTY	LIST PRICE EA	
I	EV961722	2CB5-S Cartridge	3,000 / 11,356	6	\$29.04
J	EV961726	4CB5-S Cartridge	6,000 / 22,712	6	40.04

*See individual system specification sheets for performance claims and FIFRA registration information.

**KDF media inhibits scale buildup that can damage equipment.

Filter Heads

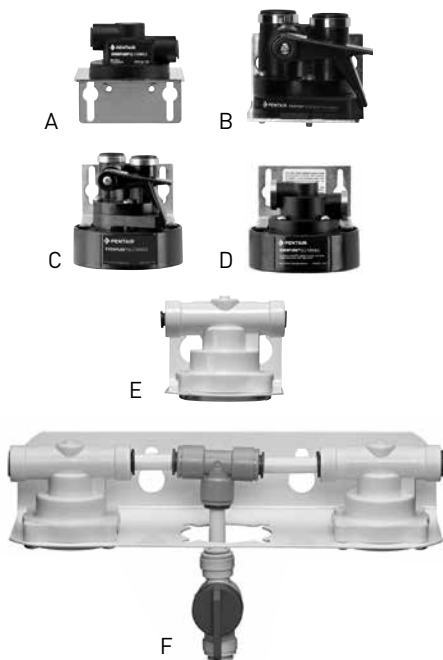

PART NO	DESCRIPTION	PACK QTY	FITTINGS	LIST PRICE EA
A EV925620	QL1 Single Head: without shutoff, includes bracket.	24	1/4" John Guest® (JG)	\$20.33
A EV925617	QL1 Single Head: without shutoff, includes bracket.	24	3/8" JG	20.33
A EV925618	QL1 Single Head: without fittings	24	3/8" FPT	19.46
A EV925619	Filter Head: with reversed inlet and outlet, (bracket designed to match competitive mounting holes).	24	3/8" FPT	19.46
- EV308132	Male Connector: with 0.5 gpm [1.89 Lpm] flow control for OW200L, OW2-Plus and OW4-Plus (3/8" NPT x 3/8" JG).	1	-	19.00
B EV925924	QL3B Single Head: with built-in shutoff valve, mounting bracket and 3/8" NPT.	12	3/8" NPT	28.92
C EV925914*	QL3* Single Head: with shutoff, mounting bracket and 3/8" NPT.	12	3/8" NPT	37.83
D EV927218*	QL2 Single Head: without shutoff, includes mounting bracket and 3/8" FPT.	24	3/8" FPT	23.67
E 357296-06**	Filter Head: with built-in auto shutoff.	50	3/8" JG	21.04
F EV979838**	Everpure Series Head	1	3/8" JG	80.42
- EV800279	Tri-Wall Baffle	1	-	0.42

Reverse Osmosis (RO) Systems & Processors



EVERPURE® ROM II RO SYSTEM

- Reverse osmosis system without storage tank
- Reduces unwanted minerals, nitrate, chlorine and sediment
- Nominal water production per day: 14 gallons [53 L] with 50 psi [3.45 bar], 77°F [25°C] inlet water temperature

PART NO	DESCRIPTION	PACK QTY	LIST PRICE EA
EV927375	ROM II RO System	1	\$312.94
EV961716	4CB5 Carbon Filter Cartridge	6	36.83
EV927369	MR-20 RO Filter Cartridge	1	248.00



EVERPURE ROM 10 & ROM 20 RO PROCESSORS

- Reduces unwanted minerals, nitrate, chlorine and sediment
- Filter heads and cartridges sold separately – choose one membrane and one filter cartridge from the selection below to build the desired system
- ROM 10 water production per day: 100.0 gallons [378.5 L]^{††}
- ROM 20 water production per day: 200.0 gallons [757.1 L]^{††}

PART NO	DESCRIPTION	PACK QTY	LIST PRICE EA
EV927226	ROM 10 / ROM 20 System Head	1	\$129.17
EV927391	ROM 10 Membrane Cartridge	1	194.58
EV927393	ROM 20 Membrane Cartridge	1	226.25
EV960705	7T0 Carbon Filter Cartridge	1	60.83
EV961811	7CB5 Carbon Filter Cartridge	1	51.67
EV961716	4CB5 Carbon Filter Cartridge	6	36.83

*Recommended for Everpure® 750 and ESO cartridges.

**Requires tri-wall baffle in cartridge.

***Filter cartridge should be changed every six (6) months.

†RO cartridge should be changed every two (2) years.

††Nominal water production with 50 psi [3.45 bar], 77°F [25°C] inlet water temperature.

Reverse Osmosis (RO) Systems

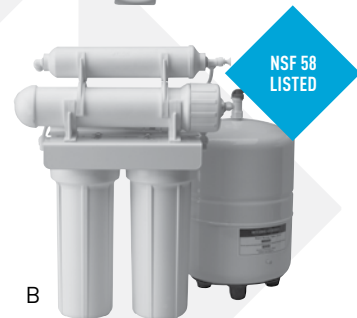

EVERPURE® LVRO-75HE RO SYSTEMS

NEW

- System includes mineral reduction processor, carbon filter cartridge, post filter carbon cartridge, high efficiency GRO-75EN Reverse Osmosis Cartridge and storage tank
- Improves equipment life and performance by removing at least 95%+ of all dissolved solids that cause scale buildup
- Especially useful on water coolers and other evaporative equipment that are not emptied each day
- EV997510 comes with a faucet

PART NO	DESCRIPTION	PACK QTY	LIST PRICE EA
A	EV997500 LVRO-75HE, Low Volume Reverse Osmosis System.	1	\$345.83
A	EV997510 LVRO-75HE+F, Low Volume Reverse Osmosis System.	1	367.50

PENTAIR® RO-2550 SYSTEM

- Filters particles as small as 1/1000 of a micron by mechanical means*
- Reduces salts, dissolved minerals and bad taste & odor
- Features GE/Desal® 50.0 gpd [136.3 Lpd] thin film composite membrane

PART NO	DESCRIPTION	PACK QTY	LIST PRICE EA
B	161079 RO-2550 4-Stage, 50.0 gpd [136.3 Lpd].	1	\$151.25

Reverse Osmosis Accessories

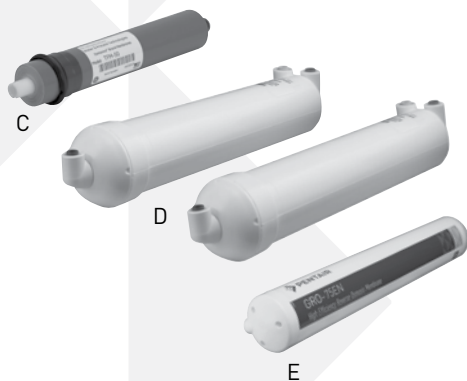

EVERPURE RO ELEMENTS & RO ENCAPSULATED MODULES

PART NO	MODEL	DESCRIPTION	PACK QTY	LIST PRICE EA
C	1204694	TFM-50 RO Element	25	\$23.71
C	1220190	TFM-36 RO Element	25	23.83
D	1223077	TFM-75 EB RO Encapsulated Module	25	53.75
D	1238189	TFM-100 EB RO Encapsulated Module	25	60.83
E	4002575	GRO-75EN RO Encapsulated Module	16	52.50

EVERPURE ACCUMULATOR TANKS & ACCESSORIES

PART NO	DESCRIPTION	PACK QTY	LIST PRICE EA
F	EV310275 Accumulator Tank: 3 gallon [11.36 L] 15.0" H x 11.0" W [38.1 H x 27.9 W cm], with base.	1	\$85.83
-	EV311655 Ball Valve: 1/4" NPT x 3/8" PI for 3 gallon [11.36 L] tank.	1	14.79
-	EV312339 Adapter: Air Gap RO, wall mount.	1	23.79
G	181-201 Accumulator Tank: 21 oz [0.62 L].	12	27.75



EVERPURE IN-10 CC IN-LINE FILTER

- Adds minerals back for flavor in coffee applications
- For use with RO systems

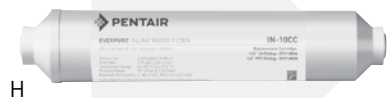

PART NO	DESCRIPTION	CAPACITY GALLONS / LITRES	FITTINGS	PACK QTY	LIST PRICE EA
H	EV910071 IN-10 CC 10" Calcite/Carbon Filter: for T&O with mineral feed.	2,000 / 7,571	1/4" FPT	6	\$13.00

*See individual system specification sheets for performance claims and FIFRA registration information.

Softening for Single Cup Coffee & Espresso Applications

EVERPURE® ESO⁶ AND ESO⁷ SOFTENING SYSTEMS

- Head and cartridges sold separately

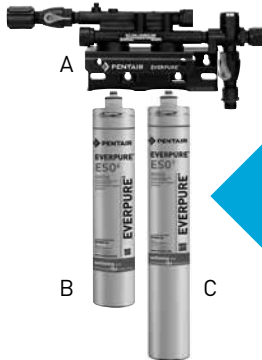

ALSO SEE CLARIS™ ON PAGE 61

PART NO	DESCRIPTION	CAPACITY		LIST PRICE EA
		SINGLE	TWIN	
A	EV927222	QC7I Twin Parallel Head		\$204.58
B	EV960710	4,100 grains	8,200 grains	68.33
C	EV960725	5,300 grains	10,600 grains	75.83

APPLICATION GUIDE	
Cartridge Capacity Grains per Gallon in Influent Water	= Total Gallons Product Water

ESO⁶ AND⁷ CARTRIDGE CAPACITY

INCOMING WATER HARDNESS (GRAINS/GALLONS)	ESO ⁶		ESO ⁷	
	VOLUME TO CHANGEOUT (GALLONS / LITRES)	NUMBER OF 8 OZ CUPS	VOLUME TO CHANGEOUT (GALLONS / LITRES)	NUMBER OF 8 OZ CUPS
3	1,363 / 5,160	21,809	1,769 / 6,696	28,300
4	1,022 / 3,869	16,357	1,327 / 5,023	21,225
6	682 / 2,582	10,905	884 / 3,346	14,150
8	511 / 1,934	8,178	663 / 2,510	10,613
10	409 / 1,548	6,543	531 / 2,010	8,490
12	341 / 1,291	5,452	442 / 1,673	7,075
14	292 / 1,105	4,673	379 / 1,435	6,064
16	256 / 969	4,089	332 / 1,257	5,306
18	227 / 859	3,635	295 / 1,117	4,717
20	204 / 772	3,271	265 / 1,003	4,245
22	186 / 704	2,974	241 / 912	3,859
24	170 / 644	2,726	221 / 837	3,538

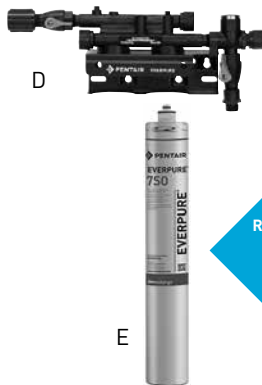

RECOMMENDED FOR SCALE CONTROL IN SINGLE CUP MACHINES

EVERPURE QC TWIN SERIES SYSTEM

- Combines precoat filtration with water softening
- Use properly-sized precoat cartridge followed by 750 Softening Cartridge
- Head and cartridges sold separately

PART NO	DESCRIPTION	CAPACITY	PACK QTY	LIST PRICE EA
D	EV927224	QC Twin Series Head	-	1 \$105.00
E	EV960704	750 Softening Cartridge	2,000 grains	1 65.83

EVERPURE SOFTENING, SYSTEM HOUSINGS/REPLACEMENT CARTRIDGES

- Housings and cartridges sold separately (except for EV910094 below)
- 15.0" [38.1 cm] resin and carbon filter for T&O reduction with hardness removal (EV910078 only)



PART NO	DESCRIPTION	CAPACITY	FITTINGS	PACK QTY	LIST PRICE EA
F	EV910002	A-11 10" Opaque Housing: for SO-10 Cartridge.	-	1/4" FPT	1 \$21.54
-	EV910003	A-20 20" Opaque Housing: for SO-20 Cartridge.	-	1/4" FPT	1 32.71
G	EV910541	SO-10 Softening Cartridge	750 grains	-	12 16.08
-	EV910542	SO-20 Softening Cartridge	1,500 grains	-	6 25.29
-	EV910094	SO-24 Softening System: Vessel & Cartridge.	4,500 grains	-	1 125.00
-	EV910545	SO-204 Softening Cartridge	4,500 grains	-	1 55.42

Replacement Cartridges for 3M®/Cuno® Series 8000 Systems



- 5 micron nominal carbon block filtration
- Reduces particulates and chlorine taste & odor

PART NO	DESCRIPTION	CAPACITY GALLONS / LITRES	PACK QTY	LIST PRICE EA
A EV975111	EFS5002-KDF® Scale Inhibition Cartridge	4,000 / 15,142	6	\$34.67
B EV978110	EFS8002 Carbon Block	10,000 / 37,854	6	35.79
C EV978112	EFS8002-S Carbon Block: with Scale Inhibitor	10,000 / 37,854	6	39.29

Scale Reduction



EVERPURE SCALESTICK® SCALE REDUCTION CARTRIDGES

- Inhibits mineral scale deposits by dispensing a controlled amount of HydroBlend™ compound
- Translucent cartridge allows visual monitoring of product usage (EV979902 only)
- Fits standard 10.0" [25.4 cm] prefilter housing

PART NO	DESCRIPTION	PACK QTY	LIST PRICE EA
D EV979902	SS-10 Scale Reduction ScaleStick	12	\$42.08
- EV979904	SSW-10 Wrap ScaleStick	12	39.46
E EV979905	SWS-10 Sediment Filter Wrap Cartridge	12	12.17
F EV979906	CWS-10 Carbon Block Filter Wrap Cartridge	12	26.33

EVERPURE 10" [25.4 CM] FILTER HOUSING

- For use with ScaleStick Scale Reduction Cartridges and Wrap ScaleStick (above)

PART NO	DESCRIPTION	PACK QTY	LIST PRICE EA
G EV910001	A-10 Clear Housing: for ScaleStick	1	\$24.92
- EV910002	A-11 Opaque Housing	1	21.54

Replacement Parts

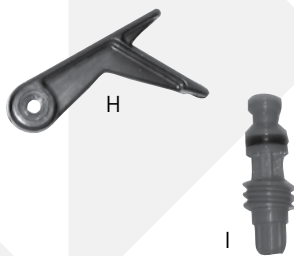

PART NO	DESCRIPTION	PACK QTY	LIST PRICE EA
H EV300800	Black Valve Handle: for brass head.	1	\$2.21
H EV303452	Black Valve Handle: for plastic head.	1	1.33
- EV304644	Single Bracket	1	4.00
- EV308132	Male Connector: with 0.50 gpm [1.89 Lpm] flow control for OW200L, OW2-Plus and OW4-Plus [3/8" NPT x 3/8" John Guest® Fitting].	1	19.00
I EV589600	Valve Stem Assembly	1	4.79
- EV301000	O-Ring: for valve stem.	1	0.58
- EV310876	Header Bypass Assembly	1	4.88

Water Testing



PART NO	DESCRIPTION	PACK QTY	LIST PRICE EA
J EV650050	AquaChek 5™ Bottle of Test Strips	1	\$24.08
- EV650080*	Water Sample Bottle for Lab Analysis: 32 oz [0.95 L], not shown.	1	4.04
K EV650020	Digital Pocket TDS Meter: 0-9990 ppm TDS; temperature reading 32-176°F [0-80°C]; reading "Hold" function with soft case.	1	27.58
L EV312598	TDS Meter: disposable.	50	7.50

*Additional charges may apply for laboratory testing. Contact your local Pentair Everpure Representative or Technical Service at 1.800.942.1153 to obtain lab analysis pricing and procedures.

Filter System Housings, Replacement Cartridges

Everpure Value Filtration products by Pentair® feature six bowl-style filter housings with a selection of drop-in cartridges designed for operations with different application configurations, volume requirements and/or water quality problems.

EVERPURE® FILTER SYSTEM HOUSINGS

- Complete with gauge and shutoff; approximately 2-1/2" [6.35 cm] in diameter

PART NO	DESCRIPTION	VOLUME (CUBIC FT.)	WEIGHT (LBS./KGS)	PACK QTY	LIST PRICE EA
A EV910010	CGS-10 10" Single Bowl Housing	0.75	4.90 / 2.22	1	\$65.83
B EV910012	CGS-12 10" Twin Series Bowl Housing	0.81	7.75 / 3.52	1	107.92
- EV910020	CGS-20 20" Single Bowl Housing	1.25	6.75 / 3.06	1	97.92
- EV910022	CGS-22 20" Twin Series Bowl Housing	1.34	12.00 / 5.44	1	177.92
- EV910023	CGS-23 20" Twin Parallel Bowl Housing	1.90	18.00 / 8.16	1	171.25
- EV910050	CGS-55 20" Triple Series Bowl Housing	2.84	20.00 / 9.07	1	235.00

EVERPURE STANDARD CARTRIDGES

- Approximately 2-1/2" [6.35 cm] in diameter and available in approximately 5.0" [12.7 cm], 10.0" [25.4 cm] and 20.0" [50.8 cm] lengths
- Models available for sediment, chlorine taste & odor reduction, scale prevention

PART NO	DESCRIPTION	MICRON	VOLUME (CUBIC FT.)	WEIGHT (LBS./KG)	PACK QTY	LIST PRICE EA
Length - 10-inch [25.40 cm]						
- EV910811	CGT-10 GAC Cartridge	-	0.75	12.10 / 5.49	12	\$9.17
- EV910813	CGT-10S GAC Cartridge w/Phosphate (Bunn® Replacement)	-	0.75	12.10 / 5.49	12	12.13
C EV910815	CG5-10 Carbon Block Cartridge	5.0	0.75	14.00 / 6.35	12	10.21
- EV910817	CG5-10S Carbon Block Cartridge w/Phosphate	5.0	0.75	16.00 / 7.26	12	13.29
- EV910853	CG53-10 Carbon Block Cartridge	0.5	0.75	14.00 / 6.35	12	11.08
- EV910857	CG53-10S Carbon Block Cartridge w/Phosphate	0.5	0.75	16.90 / 7.67	12	13.92
- 155248-43	PCC212 Phosphate Crystal Cartridge: 12.0 oz / 340.2 grams	-	1.12	6.80 / 3.08	6	18.13
- 255800-43	KDF*/GAC Cartridge	-	0.62	22.80 / 10.34	12	25.04
Length - 20-inch [50.80 cm]						
- EV910832	CGT-20 GAC Cartridge	-	1.18	16.60 / 7.53	6	\$15.08
- EV910833	CGT-20S GAC Cartridge w/Phosphate	-	1.18	18.00 / 8.16	6	20.08
- EV910825	CG5-20 Carbon Block Cartridge	5.0	1.18	17.00 / 7.71	6	17.58
- EV910827	CG5-20S Carbon Block Cartridge w/Phosphate	5.0	1.18	18.00 / 8.16	6	22.58
- EV910863	CG53-20 Carbon Block Cartridge	0.5	1.18	15.00 / 6.80	6	21.67
- EV910867	CG53-20S Carbon Block Cartridge w/Phosphate	0.5	1.18	16.50 / 7.48	6	26.75
- 155016-43	P5-20 Spun Polypropylene Sediment Cartridge	5.0	1.02	9.40 / 4.26	20	5.50
Length - 9 7/8-inch [25.08 cm]						
D 155014-43	P5 Spun Polypropylene Sediment Cartridge	5.0	1.68	15.60 / 7.08	24	\$3.40
Length - 4 7/8-inch [12.38 cm]						
- 155110-43	GAC-5 Granular Activated Carbon Cartridge	-	0.66	12.30 / 5.58	24	\$7.00
- 155030-43	P5-478 Spun Polypropylene Sediment Cartridge	5.0	0.57	5.10 / 2.31	24	2.71

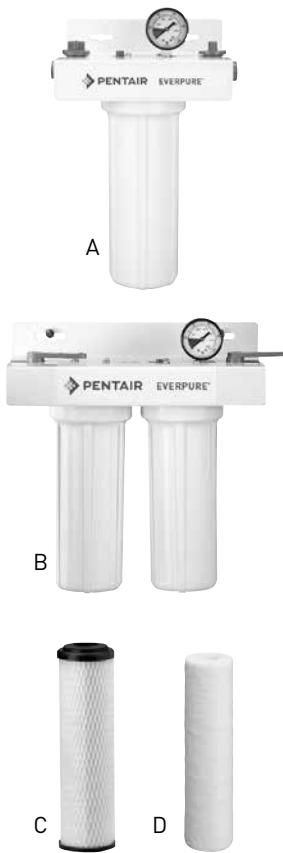

Hot Water Filtration

HIGH TEMPERATURE HOUSINGS & REPLACEMENT CARTRIDGES

- Available with 1/2" [1.27 cm] inlet/outlet connections

PART NO	DESCRIPTION	VOLUME (CUBIC FT.)	WEIGHT (LBS./KG)	PACK QTY	LIST PRICE EA
High Temperature 1/2-inch [1.27 cm] Inlet/Outlet Connections					
E 158319	#10 Slim Line Black High Temperature Housing	1.21	38.00 / 17.24	12	\$46.67
F EV910815	CG5-10 Carbon Block Cartridge	0.75	14.00 / 6.35	12	10.21

*KDF media inhibits scale buildup that can damage equipment.



Water Appliances



EVERPURE® INSTANT HOT WATER DISPENSER

- Piping hot water available on demand at 190.0°F [87.8°C]
- Produces 100-8 oz [0.24 L] cups of water per hour
- Compact unit mounts on wall or inside virtually any cabinet
- Insulated stainless steel tank is energy efficient and maintenance-free
- Powerful 1300 watts for quicker recovery
- Fingertip temperature adjustment
- Easy to install with quick connect fittings
- Self-resetting thermal fuse protects heating element by preventing accidental dry starts
- UL listed

PART NO	DESCRIPTION	DIMENSIONS	PACK QTY	LIST PRICE EA
EV931840	Instant Hot Water Dispenser	11.2" H x 6.8" W x 8.1" D 28.4 cm H x 17.3 cm W x 20.6 cm D	1	\$202.28



EVERPURE POLARIA® WATER CHILLER

- Chills to an ideal temperature of 50°F
- Produces 1.3 gallons [4.9 L] chilled water per hour
- 0.7 gallon [2.6 L] internal tank
- Whisper quiet, hermetically sealed, and maintenance-free compressor
- Uses ozone-friendly refrigerant
- Consumes only 155 watts of electricity when compressor is cycling
- Stainless steel components and lead-free design
- Accessory power cord included
- UL listed

PART NO	DESCRIPTION	DIMENSIONS	PACK QTY	LIST PRICE EA
EV931830	Polaria Water Chiller	14" H x 7" W x 17" D 35.6 cm H x 17.8 cm W x 43.2 cm D	1	\$597.57

Appliance Accessories

EVERPURE DUAL-TEMP WATER APPLIANCE FAUCETS



EV900085*
Polished Stainless Steel



EV900086*
Brushed Stainless Steel

PART NO	LIST PRICE EA
EV900085	\$270.74
EV900086	270.74

EVERPURE DESIGNER WATER APPLIANCE FAUCETS*

Everpure Designer Drinking Water Faucets deliver a steady stream of premium quality filtered water from Everpure Water Filtration Systems. These faucets (sold separately) are available in eight stunning finishes and colors to match any office decor.

Ceramic disc-type valve – won't leak and no O-rings to replace.



EV997056*
Chrome



EV997059*
Brushed Nickel



EV997060*
Oil Rubbed Bronze



EV997061*
Satin Nickel

PART NO	LIST PRICE EA
EV997056	\$100.37
EV997059	100.37
EV997060	100.37
EV997061	100.37

*Approved for use in California.

- Helps boost water up to the recommended pressure for single cup systems
- Can be used as a post-RO booster system for water-using equipment
- Boosts water pressure on long line runs from water-using equipment so 100 feet of line is no longer an issue
- Increases filter life

SHURFLO® MINI WATER BOOST SYSTEMS

Designed for applications where low, fluctuating, or no water pressure exists.



- Features reliable Shurflo 8025 Series Pumps
- Pumps and tanks are NSF-, UL- and CSA-listed
- Can run dry without damage
- Self-priming up to 8.0 vertical feet [2.4 m]
- Pump and accumulator tank maintain consistent water pressure to one or more dispensing valves or faucets

PART NO	DESCRIPTION	PRESSURE		FLOW		AMPS	PACK QTY	LIST PRICE EA
		PSI	BAR	GPM	LPM			
804-002	115 VAC, 90 PSI [6.2 bar], includes 8025-933-399 Pump, 3/8" [10 mm] barb fittings, 21 oz [0.62 L] [air/liquid] tank, 10.3" W x 10.0" H x 4.6" D [26.2 cm W x 25.4 cm H x 11.7 cm D], corded.	20	1.4	1.42	5.40	0.48	1	\$172.55
		40	2.8	1.26	4.80	0.61		
		60	4.1	1.13	4.30	0.73		
		90	6.2	0.68	2.60	0.90		
804-042	3/8" barb, [10 mm], 90 PSI [6.21 bar] shutoff, 21 oz [621 ml] Shurflo tank; 100-240 VAC 50/60 Hz, 120 Watt, 24 VDC 5.0 Amps, US, Australia/New Zealand Plug (IEC320/C13 female power cord adapter); additional cords for Europe available. 3.9' [1.2 m] power cord and 3.2' [1.0 m] low voltage cord with AMP connector; UL, CUL, CE, C-Tick, TÜV/GS, PSE and EK recognized. 8025-998-338 pump. AMPS at 24 VDC.	20	1.4	1.30	5.40	N/A	1	212.50
		40	2.8	1.25	4.80	N/A		
		60	4.1	1.15	4.40	3.00		
		90	6.2	1.00	3.80	3.80		
		100	6.9	0.95	3.60	4.20		

SHURFLO MEDIUM ELECTRIC WATER BOOST SYSTEMS

Designed for applications where low, fluctuating, or no water pressure exists.



- Features reliable Shurflo 8000 Series Pumps
- Pumps and tanks are NSF-, UL- and CSA-listed
- Can run dry without damage
- Self-priming up to 8.0 vertical feet [2.4 m]
- Pump and accumulator tank maintain consistent water pressure to one or more dispensing valves or faucets

PART NO	DESCRIPTION	PRESSURE		FLOW		AMPS	PACK QTY	LIST PRICE EA
		PSI	BAR	GPM	LPM			
804-023	115 VAC, 90 PSI [6.2 bar], includes 8025-933-399 Series Pump, 3/8" [10 mm] barb fittings, 2.0 gallon [7.6 L] stainless steel tank, 10.0" W x 13.0" H x 10.0" D [25.4 cm W x 33.0 cm H x 25.4 cm D].	20	1.6	1.42	5.40	0.48	1	\$292.16
		40	2.8	1.25	4.80	0.61		
		60	4.1	1.13	4.30	0.73		
		90	6.2	0.68	2.60	0.90		

WATER BOOST SYSTEMS

SHURFLO® MEDIUM ELECTRIC WATER BOOST SYSTEMS (CONT'D)



PART NO	DESCRIPTION	PRESSURE		FLOW		AMPS	PACK QTY	LIST PRICE EA
		PSI	BAR	GPM	LPM			
804-029	230 VAC, 90 PSI [6.2 bar], includes 8095-942-349 Series Pump, 3/8" [10 mm] barb fittings, 2.0 gallon [7.6 L] stainless steel tank, 10.0" W x 13.0" H x 10.0" D [25.4 cm W x 33.0 cm H x 25.4 cm D], non-corded.	20	1.4	1.47	5.40	0.48	1	\$307.84
		40	2.8	1.25	4.80	0.61		
		60	4.1	1.13	4.30	0.73		
		90	6.2	0.68	2.60	0.90		
804-066	115 VAC, 60 PSI [4.1 bar] shutoff, 2.0 gallon [7.6 L] stainless steel Shurflo Tank w/replacement bladder; inlet/outlet 3/8" [10 mm] stainless steel barb fittings, 8025-833-336, corded pump.	20	1.4	1.42	5.40	0.23	1	292.16
		40	2.8	1.26	4.80	0.61		
		60	4.1	1.13	4.30	0.73		
804-034	3/8" barb, [10 mm], 90 PSI [6.21 bar] shutoff, 2.0 gallon [7.6 L] Shurflo Tank w/replaceable bladder; 100-240 VAC 50/60 Hz, 120 Watt, 24 VDC 5.0 Amps, US, Australia/ New Zealand Plug (IEC320/C13 female power cord adapter); additional cords for Europe available. 3.9' [1.2 m] power cord and 3.2' [1.0 m] low voltage cord with AMP connector; UL, CUL, CE, C-Tick, TÜV/GS, PSE and EK recognized. 8025-998-338 pump. AMPS at 24 VDC.	20	1.4	1.30	4.90	N/A	1	329.17
		40	2.8	1.25	4.70	N/A		
		60	4.1	1.15	4.40	3.00		
		90	6.2	1.00	3.80	3.80		
		100	6.9	0.95	3.60	4.20		

REVERSE OSMOSIS PUMPS

- Helps boost water pressure prior to a reverse osmosis (RO) system to help make it run more efficiently
- Boosts water pressure on long line runs
- Increases filter life

SHURFLO 80 SERIES RO BOOSTER SYSTEM

Features a high quality, continuous-duty pump.

- Reliable pump head and motor
- Safe, low-voltage motor
- Safe, constant pressure to RO systems
- Quiet, continuous operation
- Includes full tank shutoff switch
- Can be wall mounted



PART NO	DESCRIPTION	PRESSURE		FLOW		AMPS	PACK QTY	LIST PRICE EA
		PSI	BAR	GPH	LPH			
80-121-18	Without enclosure, flow up to 50 gpd [189 Lpd] (8010-101-200 pump configuration). Booster pump with tank switch and transformer, 115/24 VAC/VDC, 120 PSI [8.3 bar], 3/8" [10 mm] FPT ports.	20	1.4	7.52	28.00	0.21	6	\$125.49
		40	2.8	6.33	24.00	0.27		
		60	4.1	5.48	22.00	0.34		
		90	6.2	0.60	2.30	0.41		

- Helps boost water pressure prior to a reverse osmosis (RO) system to help make it run more efficiently
- Boosts water pressure on long line runs
- Increases filter life



SHURFLO® 8075 HIGH PERFORMANCE BRUSHLESS D.C. RO BOOSTER PUMP

Versatility, high efficiency and long life.

- High flow rate supports 150 - 200+ gpd [570 - 760+ Lpd] systems at standard recovery rates
- Quiet operation at any flow and pressure range
- Extended motor life with brushless technology
- Pressures up to 140 PSI [9.6 bar]
- Power supply required – see page 19

PART NO	DESCRIPTION	PRESSURE		FLOW		AMPS	PACK QTY	LIST PRICE EA
		PSI	BAR	GPH	LPH			
8075-192-319	24 VAC/VDC, 200 gpd [760 Lpd], 140 PSI [9.6 bar], bypass 3/8" -18 NPT, NSF-listed.	80	5.5	47.00	178.00	2.5	6	\$121.08
		100	6.9	41.00	155.00	2.5		
		120	8.3	32.00	121.00	2.5		



SHURFLO 8075 SILVER SERIES RO BOOSTER PUMP

Quality and reliability in its one-piece design.

- Ultra-quiet operation
- Ideal for 50 - 150 gpd [189 - 570 Lpd] applications
- Patented diaphragm and bypass design
- Reliable, long-lasting performance
- Economical price point
- Power supply required – see page 19 for 60-044-00

PART NO	DESCRIPTION	PRESSURE		FLOW		AMPS	PACK QTY	LIST PRICE EA
		PSI	BAR	GPH	LPH			
8075-111-319	24 VAC/VDC, 50 gpd [189 Lpd], 90 PSI [6.2 bar], bypass 3/8" [10 mm] NPT, NSF-listed.	20	1.4	17.00	61.40	0.22	6	\$90.69
		40	2.8	14.00	53.00	0.32		
		60	4.1	11.00	41.60	0.42		
		90	6.2	7.00	26.50	0.56		



SHURFLO 82 SERIES LOW VOLTAGE DELIVERY SYSTEM

Delivery pump system can be used to boost water to the faucet after the RO tank. Ready to use... simply plumb, plug in and you're in operation.

- Flow rates up to 0.90 gpm [3.4 Lpm]
- Self-primers up to 7.0 feet [14.9 m]
- Low-voltage 24 VAC/VDC
- UL-listed transformer
- Select models include a low-pressure switch that shuts off the pump when the pressure is 3 PSI [0.2 bar], and turns on when the inlet pressure is 8 PSI [0.5 bar]

PART NO	DESCRIPTION	PRESSURE		FLOW		AMPS	PACK QTY	LIST PRICE EA
		PSI	BAR	GPM	LPM			
82-100-00	0.9 gpm [3.4 Lpm], 100-240/24 VAC/VDC, UL-listed transformer, 60 PSI [4.1 bar], demand switch, 3/8" [10 mm] inlet/outlet fittings, low pressure switch, NSF-listed.	20	1.4	0.89	3.40	1.21	1	\$164.71
		40	2.8	0.74	2.80	1.43		
		60	4.1	0.41	1.60	1.62		
		90	6.2	0.01	0.01	1.81		

REVERSE OSMOSIS PUMPS & ACCESSORIES

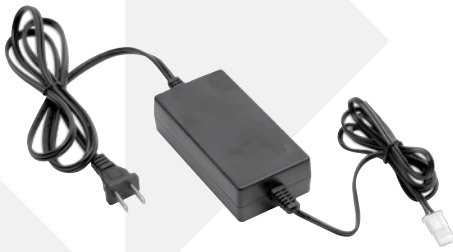

SHURFLO® POWER SUPPLY / TRANSFORMER

- Switch-made design makes it energy efficient
- For RO booster pumps only

PART NO	DESCRIPTION	PACK QTY	LIST PRICE EA
60-044-00	100-240 VAC 50/60 Hz 1.2 Amps, 24 VDC 2.5 Amps, US plug, 4.50' [1.37 m] power cord and 4.50' [1.37 m] low voltage cord with AMP connector.	24	\$16.32
94-60-047	Replacement power supply for 24 VDC Water Boost Pumps: 100-240 VAC 50/60 Hz, 120 Watt, 24 VDC 5.0 Amps, US, Australia/New Zealand Plug (IEC320/C13 female power cord adapter). Additional cords for Europe available. 3.9' [1.2 m] power cord and 3.2' [1.0 m] low voltage cord with AMP connector; UL, CUL, CE, and C-Tick recognized. Water Boost Systems only.	1	83.82

ELECTRIC DELIVERY PUMPS

- Connect water cooler with pump to a coffee brewer for convenient drinking water on-demand
- Great for use on bottled water filling stations
- Ideal water vending machine replacement pump (3.3 gpm)

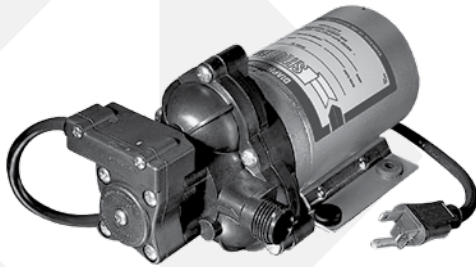

SHURFLO 2088 SERIES PUMP

High-flow, low-pressure pump ideally suited for beverage and water applications.

- Self-priming up to 12.0 vertical lift feet [3.7 m]
- Used in delivery and transfer applications up to 3.0 gpm [11.4 Lpm]
- UL/CSA-recognized components
- Built-in check valve (may vary by model) prevents backflow of fluid
- Automatic turn on/shutoff
- Can run dry without damage
- Customer-provided power supply required

PART NO	DESCRIPTION	PRESSURE		FLOW		AMPS	PACK QTY	LIST PRICE EA
		PSI	BAR	GPM	LPM			
2088-594-144	115 VAC, 3.3 gpm [12.5 Lpm] open flow, Santoprene® valves, Santoprene diaphragm, 45 PSI [3.1 bar], shutoff, 1/2"-14* NPT male ports, NSF-, UL-, and CUL-listed, corded.	10	0.7	2.60	9.80	0.58	6	\$120.59
		20	1.4	2.34	8.80	0.67		
		30	2.1	2.08	7.90	0.76		
		40	2.8	1.85	6.20	0.94		

*1/2"-14 thread ports require Shurflo swivel fittings.

Everpure® Office Coffee Service, Office Water & Vending Products

This chart presents a range of Everpure brand water solutions for office coffee service, office water and vending applications. By comparing basic performance features, you can make an informed decision about which filtration system is right for you.

NSF International, The Public Health and Safety Company™, a not-for-profit, non-governmental organization, is the world leader in standards development, product certification, education, and risk-management for public health and safety.

NSF has developed key standards for the evaluation and certification of drinking water treatment units, and many Everpure filtration systems have been certified to those standards. Whenever possible, make sure your filters carry a "Tested and Certified by NSF" mark.



NSF STANDARD 42

Covers specific aesthetic or non-health-related contaminants such as chlorine taste & odor, and particulates that may be present in drinking water.

NSF STANDARD 53



































Covers specific health-related contaminants such as Cryptosporidium and Giardia Cysts, lead, asbestos and volatile organic chemicals (VOCs) that may be present in drinking water.

PART NUMBER	MODEL	CHLORINE TASTE & ODOR REDUCTION	SCALE INHIBITION	KDF® SCALE INHIBITION*	PARTICULATE REDUCTION*	SUBMICRON TURBIDITY REDUCTION	ASBESTOS REDUCTION	LEAD REDUCTION	CYST REDUCTION†**	CHLORAMINES REDUCTION	BACTERIOSTATIC CONTROL†**	BACTERIA REDUCTION†**	CAPACITY GALLONS / LITRES	NSF Certification
EV910066	IN-6 CG-S	✓	✓										585 / 2214	
EV910067	IN-6 PG-S		✓										6 months	
EV910008	IN-10	✓	✓										2,400 / 9,085	
EV910007	IN-12	✓	✓										4,800 / 18,169	
EV910068	IN-10 CK	✓		✓							✓		5,000 / 18,927	
EV961836	2CB-GW	✓	✓		✓								3,000 / 11,356	
EV961705	2CB5	✓			✓								3,000 / 11,356	
EV961722	2CB5-S	✓	✓		✓								3,000 / 11,356	
EV961706	2CB5-K	✓		✓	✓						✓		3,000 / 11,356	
EV961716	4CB5	✓			✓								6,000 / 22,712	
EV961726	4CB5-S	✓	✓		✓								6,000 / 22,712	
EV961736	4CB5-K	✓		✓	✓						✓		6,000 / 22,712	
EV960112	AC	✓			✓		✓		✓				750 / 2,839	
EV961807	OCS²	✓	✓		✓		✓		✓		✓		1,500 / 5,678	
EV960100	4C	✓			✓				✓				3,000 / 11,356	
EV961100	4H	✓	✓		✓				✓				3,000 / 11,356	
EV961251	BH²	✓	✓		✓				✓		✓		3,000 / 11,356	
EV963406	OW2-Plus	✓		✓	✓		✓	✓	✓		✓		1,000 / 3,785	

*As tested by Pentair Everpure.

**See individual system specification sheets for performance claims and FIFRA registration information.

†By mechanical means.

PART NUMBER	MODEL	CHLORINE TASTE & ODOR REDUCTION	SCALE INHIBITION	KDF® SCALE INHIBITION*	PARTICULATE REDUCTION*	SUBMICRON TURBIDITY REDUCTION	ASBESTOS REDUCTION	LEAD REDUCTION	CYST REDUCTION†**	CHLORAMINES REDUCTION	BACTERIOSTATIC CONTROL†**	BACTERIA REDUCTION†**	CAPACITY GALLONS / LITRES	NSF Certification
EV963506	OW4-Plus	✓		✓	✓			✓	✓		✓		2,000 / 7,571	 
EV961906	OW200L	✓	✓		✓			✓	✓				480 / 1,817	 
EV963701	MicroGuard® Pro 2	✓			✓		✓		✓			✓	2,200 / 83,28	
EV963702	MicroGuard Pro 4	✓			✓		✓		✓			✓	3,600 / 13,627	
EV961266	2K-Plus	✓		✓	✓		✓		✓		✓		1,500 / 5,678	 
EV961276	4K-Plus	✓		✓	✓				✓		✓		3,000 / 11,356	 
EV963426	2H-L	✓	✓		✓			✓	✓				750 / 2839	 
EV963526	4H-L	✓	✓		✓			✓	✓				1,000 / 3,785	 
EV433910	Claris™ S	✓	✓										450 / 1,703	
EV433911	Claris M	✓	✓										790 / 2,991	
EV433912	Claris L	✓	✓										1,480 / 5,602	
EV433913	Claris XL	✓	✓										2,120 / 8,026	
EV433914	Claris XXL	✓	✓										3,490 / 13,211	
EV433980	Claris Ultra S	✓	✓										660 / 2,500	 Pending
EV433981	Claris Ultra M	✓	✓										1,109 / 4,200	 Pending
EV433982	Claris Ultra L	✓	✓										2,245 / 8,500	 Pending
EV433983	Claris Ultra XL	✓	✓										3,196 / 12,100	 Pending
EV433984	Claris Ultra XXL	✓	✓										5,283 / 20,000	 Pending
EV969286	2CLM	✓			✓	✓			✓	✓			1,500 / 5,678	
EV969296	2CLM-S	✓	✓		✓	✓			✓	✓			1,500 / 5,678	
EV969156	2FC	✓			✓				✓		✓		6,000 / 22,700	 
EV969166	2FC5	✓									✓		6,000 / 22,700	
EV969176	2FC-S	✓	✓		✓				✓		✓		6,000 / 22,700	 
EV969186	2FC5-S	✓	✓								✓		6,000 / 22,700	 
EV969310	4FC-L	✓			✓	✓		✓	✓		✓	✓	4,900 / 28,012	 
EV969316	4FC-LS	✓	✓		✓	✓		✓	✓		✓	✓	4,900 / 28,012	 

*As tested by Pentair Everpure.

**See individual system specification sheets for performance claims and FIFRA registration information.

†By mechanical means.

Claris™ is a trademark of Aquis, GmbH.

PRICE LIST/INDEX



PART NUMBER	DESCRIPTION	2016 LIST PRICE EA	PAGE NUMBER
158149	3/8" #10 SL WHITE W/PR 12/C	\$8.17	-
158319	#10SL BLK NYL WO/PR 12/C	\$46.67	14
161074	PENTEK RO-2500, 4 STAGE RO	\$168.33	-
161079	RO-2550, 4 STAGE RO SYSTEM	\$151.25	11
244454	INLINE CLIP, #COSW, 2"	\$1.67	8
244455	INLINE CLIP, #CSWM, 2.5"	\$1.24	8
1204694	ELEMENT,NSF,DESAL,TFM-50	\$23.71	11
1220190	ELEMENT, NSF, DESAL, TFM-36	\$23.83	11
1221122	ELEMENT,NSF,DESAL,TFM-100	\$28.79	-
1223077	ELEMENT,ENCAP,TFM-75EB	\$53.75	11
1238189	ELEMENT,ENCAP,TFM-100EB	\$60.83	11
4002575	RO MEMBRANE ASSY - GRO-75EN	\$52.50	11
155014-43	CART P5 SED IND SHR 24/C	\$3.40	14
155016-43	P5-20 IND SHR UPC 20/C	\$5.50	14
155030-43	CART P5-478 IND SHR 24/C	\$2.71	14
155110-43	CART GAC-5 IND SHR 24/C	\$7.00	14
155225-43	CART P1 SED IND SHR 24/C	\$3.08	-
155248-43	CART PCC212 IND BOX 6/C	\$18.13	14
181-201	ACCUM TANK NYL/BUTYL	\$27.75	11
183-130-NF	30 PSI WPRV W/O FITTINGS, 12/C	\$17.30	2
183-150-NF	50 PSI WPRV W/O FITTINGS, 12/C	\$17.30	2
183-165-NF	65 PSI WPRV W/O FITTINGS, 12/C	\$17.30	2
183-165-QC14	1/4" JG 65 PSI COW WPRV	\$21.91	2
183-165-QC38	3/8" JG 65 PSI COW WPRV	\$21.91	2
2088-594-144	PMP 115VAC 3.0 40 PSI	\$120.59	2
21-1500-00	WALL CLIP BASE	\$9.26	8
255525-43	MU-GS-10RO-G, INLINE, 12/C	\$9.38	8
255553-43	MU-GS-10EXTRA-5-B, INLINE, 12/C	\$12.29	8
255579-43	MU-GS-10SED/5-G, INLINE, 12/C	\$13.07	8
255583-43	MU-GS-210SED/5-G, INLINE, 12/C	\$14.77	-
255599-43	MU-GS-10ALS-G, INLINE, 12/C	\$12.46	8
255615-43	RE-GS-10CB1-G INLINE 12/C	\$16.75	8
255649-43	MU-GS-10LS-G, INLINE, 12/C	\$19.33	8
255800-43	PENTEK UDS-10EX1 CART, 12/C	\$25.04	14
357296-06	MANIFOLD SINGLE EVP QCP 3/8"	\$21.04	10
455903-43	FLOPLUS 10, PENTEK (12/C)	\$14.25	-
60-044-00	SWITCHING POWER SUPPLY	\$16.32	19
80-121-18	GOLD SERIES RO BOOSTER, 6PK	\$125.49	17
804-002	M-WATER BOOST SYST 90 PSI	\$172.55	16
804-023	MED. WBS W/PMP	\$292.16	16
804-029	MED.WBS W/230V PMP ONSIDE	\$307.84	17
804-034	MEDIUM WATER BOOST 3/8 BARB AU	\$329.17	17
804-042	MINI WATER BOOST 3/8 BARB AU	\$212.50	16
804-066	MED WBS W/PMP 60PSI	\$292.16	17
8075-111-319	PUMP 24VAC R.O. GENERAL	\$90.69	18
8075-132-313	PMP 24VDC RO BOOST	\$99.02	-
8075-192-319	SLVR SERIES RO 24V 200GPD	\$121.08	18
82-100-00	LOW VOLTAGE DELIVERY SYST	\$164.71	18
84-1204-00	BALL VALVES W/O-RINGS KIT	\$41.76	8
94-399-00	LVPO F1 REPLACEMENT 12PK	\$50.49	-
94-470-00	LVPO-F2 REPLACEMENT 12PK	\$56.37	-
94-470-01	LVPO-F3 REPLACEMENT 12PK	\$58.82	8
94-470-02	LVPO F4 12PK REPL. FILTER	\$83.82	-
94-471-01	1/2" NNP QD BALL VAL [50]	\$41.76	-
94-473-00	FILTER-WALL CLIP LVPO[50]	\$18.38	-
94-475-00	FILTER BYPASS KIT [50]	\$21.13	-
94-479-00	SHURGUARD LVPO F2 ASSY	\$68.14	-
94-60-047	120W SWITCHING POWER SUPPLY AU	\$83.82	19
94-751-00	SHURGUARD LVPO F1 ASSY	\$62.25	-

PART NUMBER	DESCRIPTION	2016 LIST PRICE EA	PAGE NUMBER
94-751-01	SHURGUARD LVPO F3 ASSY	\$76.47	8
94-751-02	SHURGUARD LVPO F4 ASSY	\$94.12	-
DEV983000	CARTRIDGE HQ-WF 12/C	\$19.50	-
DEV983001	CARTRIDGE HQS-WF 12/C	\$20.46	-
EV300800	VALVE HANDLE BLACK MOLD	\$2.21	13
EV301000	O-RING .5310D X .103CS	\$0.58	13
EV303452	BLK VALVE HANDLE/PL HEAD	\$1.33	13
EV304644	BRKT POWDER COATED	\$4.00	13
EV308132	MALE CONNECTOR W/FC ASSY	\$19.00	13
EV310275	B TANK ACCUMULATOR 3 GAL	\$85.83	11
EV310876	HEADER BYPASS PLUG ASSM	\$4.88	13
EV311655	VALVE BALL, 1/4 NPTF X 3/8 PI	\$14.79	11
EV311840	IN-CLIP2 100/C	\$1.63	2
EV311842	IN-UV-BAL 25/C	\$35.17	-
EV312148	FAUCET BASE SET, 8 COLORS	\$88.75	-
EV312339	ADAPTER, AIR GAP RO WALL MOUNT	\$23.79	11
EV312491	REGULATOR, CO2,DISPOSABLE CART	\$219.58	-
EV312492	REGULATOR, CO2,REFILLABLE CART	\$253.75	-
EV312493	FLOW COMPENSATOR, CO2	\$94.17	-
EV312598	TDS METER ASM, DISPOSABLE,50PK	\$7.50	13
EV313526	1/2" X 1/4" QC FITTING 2/BAG	\$11.18	2
EV313527	1/2" X 3/8" QC FITTING 2/BAG	\$11.18	2
EV313861	ADAPTOR, 3/4MGHT X 3/4MGHT	\$1.33	2
EV433910	CLARIS CART S	\$105.00	7, 21
EV433911	CLARIS CART M	\$147.72	7, 21
EV433912	CLARIS CART L	\$189.41	7, 21
EV433913	CLARIS CART X L	\$224.93	7, 21
EV433914	CLARIS CART XXL	\$346.40	7, 21
EV433921	CLARIS HEAD 3/8" BSP	\$79.26	7
EV433923	CLARIS HEAD 3/8" QFC	\$79.26	7
EV433925	CLARIS HEAD 1/4" QFC	\$79.26	7
EV433931	CLARIS FLOW METER US	\$134.17	-
EV433940	CLARIS TEST KIT	\$29.13	7
EV433952	CLARIS HOSE SET 10CM,3/8 X 1/2	\$37.78	-
EV433980	CLARIS ULTRA CARTRIDGE 250	\$119.93	6, 21
EV433981	CLARIS ULTRA CARTRIDGE 500	\$167.28	6, 21
EV433982	CLARIS ULTRA CARTRIDGE 1000	\$231.10	6, 21
EV433983	CLARIS ULTRA CARTRIDGE 1500	\$275.37	6, 21
EV433984	CLARIS ULTRA CARTRIDGE 2000	\$408.16	6, 21
EV433986	CLARIS PRIME	\$308.33	-
EV433990	CLARIS GEN2 HEAD L/R 3/8" BSP	\$52.08	-
EV433991	CLARIS GEN2 HEAD L/R 3/8" NPT	\$52.08	-
EV433992	CLARIS GEN2 HEAD L/R 3/8" QCF [JG]	\$52.08	-
EV589600	VALVE STEM SUB-ASSEMBLY	\$4.79	13
EV650020	POCKET TDS METER HM TDS-3 1PK	\$27.58	13
EV650050	AQUACHEK 5 TEST KIT	\$24.08	13
EV650057	TEST KIT 8 WAY STRIP 25EA/BAG	\$3.58	-
EV650080	WATER SAMPLE BOTTLE 16 OZ	\$4.04	13
EV800279	TRI WALL BAFFLE	\$0.42	10
EV900085	FAUCET, HOT/COLD POLISHED SS	\$270.74	15
EV900086	FAUCET, HOT/COLD BRUSHED SS	\$270.74	15
EV900087	FAUCET, HELIA TM BSS, 1PK	\$326.32	-
EV910001	A-10 FILTER HOUSING 1PK	\$24.92	13
EV910002	A-11 FILTER HOUSING 1PK	\$21.54	12, 13
EV910003	A-20 FILTER HOUSING 1PK	\$32.71	12
EV910006	IN-10 1/4" JG FITTING 6PK	\$10.34	8
EV910007	IN-12 1/4" FPT FITTING 6PK	\$8.05	8, 20
EV910008	IN-10 1/4" FPT FITTING 6PK	\$7.29	8, 20
EV910010	CGS-10 SYSTEM	\$65.83	14

PRICE LIST/INDEX

PART NUMBER	DESCRIPTION	2016 LIST PRICE EA	PAGE NUMBER
EV910012	CGS-12 SYSTEM	\$107.92	14
EV910020	CGS-20 SYSTEM	\$97.92	14
EV910022	CGS-22 SYSTEM	\$177.92	14
EV910023	CGS23 20" PARALLEL PLUMBED HSG	\$171.25	14
EV910050	CGS-55 SYSTEM	\$235.00	14
EV910067	IN-6PG-S 6 PK	\$10.39	8, 20
EV910068	IN-10CK 6/C	\$12.94	8, 20
EV910069	IN-10CS 6/C	\$9.88	-
EV910071	IN-10CC 6/C	\$13.00	11
EV910072	IN-10NS5 6/C	\$10.58	-
EV910073	IN-10CL1 6/C	\$20.63	-
EV910086	IN-12 1/4" JG FITTING 6PK	\$18.67	8
EV910094	SO-24 FILTER 1PK	\$125.00	12
EV910541	SO-10 COSTGUARD CART 6/C	\$16.08	12
EV910542	SO-20 6/C	\$25.29	12
EV910545	SO-204 CARTRIDGE 4PK	\$55.42	12
EV910811	CGT-10 12/C	\$9.17	14
EV910813	CGT-10S 12PK	\$12.13	14
EV910815	CG5-10 12/C	\$10.21	14
EV910817	CG5-10S 12PK	\$13.29	14
EV910825	CG5-20 6/C	\$17.58	14
EV910827	CG5-20S 6/C	\$22.58	14
EV910832	CGT-20 6/C	\$15.08	14
EV910833	CGT-20S 6PK	\$20.08	14
EV910853	CG53-10 12/C	\$11.08	14
EV910857	CG53-10S 12PK	\$13.92	14
EV910863	CG53-20 6PK	\$21.67	14
EV910867	CG53-20S 6/C	\$26.75	14
EV925617	QL1 HEAD 24PK	\$20.33	10
EV925618	QL1 HEAD 3/8" NPT 24PK	\$19.46	10
EV925619	QL1 HD RVRSD W 3/8" FPT 24PK	\$19.46	10
EV925620	QL1 HEAD WITH 1/4" JG 24PK	\$20.33	10
EV925622	QL1 HD NRW BRKT 1/4" JG, 24PK	\$19.50	-
EV925914	QL3 HO-P W/BRKT MTD 12PK	\$37.83	10
EV925924	QL3B HEAD ASSY 12PK	\$28.92	10
EV925930	QL3B W.BRKT NARROW, 12 PK	\$28.92	-
EV927218	QL2 HEAD W/BRKT 12PK	\$23.67	10
EV927222	QC7I TWIN HEAD ONLY 1PK	\$204.58	12
EV927224	EVERPURE SERIES HEAD	\$105.00	12
EV927226	HEAD TWIN RO QC	\$129.17	10
EV927375	ROM II PROCESSOR	\$312.94	10
EV927391	CART, ROM 10, 1 PACK	\$194.58	10
EV927393	CART, ROM 20, 1 PACK	\$226.25	10
EV930090	HQS-WF SYSTEM	\$120.00	-
EV930095	HQS-WF SYSTEM WITH UV PACKAGE	\$274.58	-
EV930099	HQS-WF SYSTEM W/UV COW	\$223.75	-
EV931830	EVERPURE WATER CHILLER	\$597.57	15
EV931840	EVERPURE INSTANT HOT	\$202.28	15
EV950300	WATERBLOCK	\$27.71	2
EV950305	WATER BLOCK, 25PK	\$28.42	2
EV950320	WATERBLOCK RESET DEVICE	\$15.75	2
EV950325	WATER BLOCK RESET DEVICE, 25PK	\$16.13	2
EV953412	EC110 CARTRIDGE 12PK	\$3.21	-
EV953426	EC210 CARTRIDGE 6PK	\$5.96	-
EV959206	ADC CARTRIDGE 6PK	\$28.08	-
EV960100	4C CART 6PK	\$32.96	5, 9, 20
EV960112	AC REPLACEMENT CART 6PK	\$27.92	5, 20
EV960146	4DC CART 6PK	\$35.17	-
EV960704	7-SO CARTRIDGE 1PK	\$65.83	12

PART NUMBER	DESCRIPTION	2016 LIST PRICE EA	PAGE NUMBER
EV960705	7-TO CARTRIDGE 1PK	\$60.83	10
EV960710	ESO 6, EVERPLUS, 1PK	\$68.33	12
EV960725	ESO 7, EVERPLUS, 1PK	\$75.83	12
EV960800	JT SANITIZING CART 1PK	\$37.29	2, 7
EV960810	QC2 JT CARTRIDGE 1PK	\$37.29	2, 7
EV961100	4H CART 6PK	\$41.67	9, 20
EV961251	BH(2) CART 6PK	\$41.67	3, 5, 20
EV961266	2K PLUS CARTRIDGE 6PK	\$35.92	5, 9, 21
EV961276	4K PLUS CARTRIDGE 6PK	\$45.00	5, 9, 21
EV961326	MH(2) CART 6PK	\$60.76	-
EV961705	2CB5 CARTRIDGE 6PK	\$26.63	-
EV961706	2CB5-K CARTRIDGE 6PK	\$30.17	6, 9, 20
EV961716	4CB5 CARTRIDGE 6PK	\$36.83	9, 10, 20
EV961722	2CB5-S CARTRIDGE 6PK	\$29.04	6, 9, 20
EV961726	4CB5-S CARTRIDGE 6PK	\$40.04	6, 9, 20
EV961736	4CB5-K CARTRIDGE 6PK	\$43.33	6, 9, 20
EV961807	OCS(2) CART 6PK	\$29.54	5, 20
EV961811	CARTRIDGE, 7CB5 1PK	\$51.67	10
EV961813	OCS(2) CART 12PK	\$29.54	-
EV961836	2CB-GW CARTRIDGE 6PK	\$30.71	6, 20
EV961906	OW 200L CARTRIDGE 6PK	\$50.83	4, 21
EV963406	OW2-PLUS CARTRIDGE 6PK	\$41.33	4, 20
EV963426	2-H-L, CART 12PK	\$32.96	4, 21
EV963506	OW4-PLUS CARTRIDGE 6PK	\$50.42	4, 21
EV963526	4-H-L, CART 6PK	\$35.21	4, 21
EV963701	MICROGUARD PRO 2 CARTRIDGE 6PK	\$67.50	3, 21
EV963702	MICROGUARD PRO 4 CARTRIDGE 6PK	\$75.42	3, 21
EV969156	2FC CART 6PK	\$38.58	5, 21
EV969166	2FC5 CART 6PK	\$37.71	21
EV969176	2FC-S CART 6PK	\$42.92	5, 21
EV969186	2FC5-S CART 6PK	\$41.67	6, 21
EV969286	2CLM CARTRIDGE 6PK	\$43.75	3, 21
EV969296	2CLM-S CARTRIDGE 6PK	\$47.08	3, 21
EV969310	4FC-L CARTRIDGE	\$53.33	4, 21
EV969316	4FC-LS CARTRIDGE	\$55.83	4, 21
EV975111	EFS 5002-K REPL CART 6PK	\$34.67	13
EV978110	EFS 8002 REPL CART 6PK	\$35.79	13
EV978112	EFS 8002-S REPL CART 6PK	\$39.29	13
EV979831	SCALEKLEEN 1.75OZ E/S/F 96PK	\$2.17	7
EV979833	SCALEKLEEN 7OZ E/S/F 24PK	\$4.46	7
EV979835	SCALEKLEEN 2.2LB E/S/F 4PK	\$17.54	7
EV979838	QC AS SERIES H/O W/FV, 1 PK	\$80.42	10
EV979902	SCALESTICK 10" 12PK	\$42.08	13
EV979904	SCALESTICK SSW-10 12PK	\$39.46	13
EV979905	SEDIMENT WRAP FILT SWS-10 12PK	\$12.17	13
EV979906	CB WRAP SCALESTICK CSW-10 12PK	\$26.33	13
EV982010	EVP LONGREACH FAUCET KIT	\$52.08	-
EV997055	FAUCET, ANTIQUE BRASS, EVP	\$100.37	-
EV997056	FAUCET, CHROME, EVP	\$100.37	15
EV997057	FAUCET, ANTIQUE WINE, EVP	\$100.37	-
EV997058	FAUCET, BRIGHT BLACK, EVP	\$100.37	-
EV997059	FAUCET, BRUSHED NICKEL, EVP	\$100.37	15
EV997060	FAUCET, OIL RUBBED BRONZE, EVP	\$100.37	15
EV997061	FAUCET, SATIN NICKEL, EVP	\$100.37	15
EV997500	LVRO-75HE RO SYSTEM	\$345.83	11
EV997510	LVRO-75HE RO SYSTEM W/FAUCET	\$367.50	11



System Tested and Certified by NSF International against NSF/ANSI Standards 42 and 53 for the reduction of:

Standard No. 42 – Aesthetic Effects
Chemical Reduction
Taste and Odor
Chlorine

Mechanical Filtration
Particulate Class I
99.2% reduction of particles one-half micron and larger in size

Standard No. 53 – Health Effects
Mechanical Filtration
Turbidity
Cyst
Asbestos

The Risk of Counterfeit Filter Cartridges

- Everpure heads and cartridges are certified as systems by NSF. Using counterfeit filters results in a loss of this valuable industry certification.
- Without NSF certification, there is no assurance of performance and quality could be suspect.
- For over 80 years, Pentair Everpure has been providing quality filtration products for customers around the world, and today we're a leading brand of water treatment for foodservice. We're trusted by many of the world's largest foodservice and specialty beverage chains, as well as hundreds of thousands of independent operators.
- The majority of our cartridges are certified by NSF. This provides assurance that the system has been independently evaluated to confirm its performance.
- Certified Everpure filtration products have been submitted for testing under NSF/ANSI Standards 53 and 42.
- The certification is displayed on the cartridge's label along with the applicable NSF claims.

For further information on NSF certification, please contact Technical Service at 800.942.1153/630.307.3000 or consult the NSF website, www.nsf.org.



The importance of NSF Certification

There are important reasons to look for NSF Certification when purchasing a water filter:

- **Performance claims may be based on internal testing only.** Do you have access to all the testing procedures used? Was testing done to industry standards?
- **Sometimes stated capacities are misleading** because they may be based on only chemical (chlorine) reduction and don't take particulates into consideration. Particulates have an important role in how long a filter will last. Most often, a filter plugs from dirt before the chemical capacity is used up.
- **In capacity claims, it's not always clear what percentage of chemical contaminants are actually reduced.** For example, if there is only a 50% reduction in chlorine then higher capacities can be claimed. But is removal of only half the chlorine acceptable for quality beverages?

NSF Certification ensures that:

- The contaminant reduction claims certified are true and accurate.
- The materials of construction do not add anything unwanted to the water such as lead.
- The system is structurally sound.
- Advertising claims are true and accurate.

What is NSF?

- Founded in 1944, NSF International is a not-for-profit organization that provides public health and safety risk management solutions to companies, governments and consumers around the world.
- Its main business is to bring together experts in public health, manufacturing, and sanitation from government, industry, academia and the public to develop and administer performance standards for products which have some impact on sanitation and public health.
- NSF maintains state-of-the-art laboratories where products can be tested according to set standards.

For water filters, look for these certifications:*

- **NSF/ANSI Standard 42: Aesthetic Effects**
For water treatment systems designed to reduce specific aesthetic or non-health-related contaminants (chlorine, taste and odor, and particulates).
- **NSF/ANSI Standard 53: Health Effects**
For water treatment systems designed to reduce specific health-related contaminants, such as Cryptosporidium, Giardia, lead, volatile organic chemicals (VOCs), MTBE (methyl tertiary-butyl ether).

*It's important to read the small print when evaluating a product certification. Within Standards 42 and 53 there are different classes and contaminant removals to consider. Even though a filter is certified for a standard, it may not be certified for all of the reductions possible within that standard.

For more information, contact your regional sales representative:

David Norvalls – Midwest
TEL: 847.502.4239

Chris Williams – West
TEL: 651.503.4763

John Hiner – East
TEL: 201.960.5036



WATER QUALITY SYSTEMS

EVERPURE-SHURFLO WORLD HEADQUARTERS, 1040 MUIRFIELD DRIVE, HANOVER PARK, IL 60133 USA • FOODSERVICE.PENTAIR.COM
800.942.1153 (US ONLY) • 630.307.3000 MAIN • 630.307.3030 FAX • CSEVERPURE@PENTAIR.COM EMAIL

EVERPURE-SHURFLO AUSTRALIA, 1-21 MONASH DRIVE, DANDENONG SOUTH, VIC 3175 AUSTRALIA
011.1300.576.190 TEL • 011.61.39.562.7237 FAX • AU.EVERPURE@PENTAIR.COM EMAIL

EVERPURE-SHURFLO CHINA, 21F CLOUD 9 PLAZA, NO 1118, SHANGHAI, 200052, CHINA
86.21.3211.4588 TEL • 86.21.3211.4580 FAX • CHINA.WATER@PENTAIR.COM EMAIL

EVERPURE-SHURFLO INDIA, GREEN BOULEVARD, B-9/A, 7TH FLOOR - TOWER B SECTOR 62, NOIDA - 201301
91.120.419.9444 TEL • 91.120.419.9400 FAX • INDIACUSTOMER@PENTAIR.COM EMAIL

EVERPURE-SHURFLO EUROPE, PENTAIR WATER BELGIUM BVBA, INDUSTRIEPARK WOLFSTEE, TOEKOMSTLAAN, 30 B-2200 HERENTALS, BELGIUM
+32.(0).14.283.500 TEL • +32.(0).14.283.505 FAX • SALES@EVERPURE-EUROPE.COM EMAIL

EVERPURE-SHURFLO JAPAN INC., HASHIMOTO MN BLDG. 7F, 3-25-1 HASHIMOTO, MIDORI-KU, SAGAMIHARA-SHI KANAGAWA 252-0143, JAPAN
81.(0)42.775.3011 TEL • 81.(0)42.775.3015 FAX • INFO@EVERPURE.CO.JP EMAIL

EVERPURE-SHURFLO SOUTHEAST ASIA, 390 HAVELOCK ROAD, #04-01 KING'S CENTRE, SINGAPORE 169662
65.6768.5800 TEL • 65.6737.5149 FAX • CSEVERPURE@PENTAIR.COM EMAIL

All Pentair trademarks and logos are owned by Pentair, Inc. or its affiliates. All other registered and unregistered trademarks and logos are the property of their respective owners. Because we are continuously improving our products and services, Pentair reserves the right to change specifications without prior notice.

Pentair is an equal opportunity employer.

EV7016-50 N015 © 2015 Pentair Filtration Solutions, LLC. All Rights Reserved.